

**Spin–Orbit Coupling Effects  
in Two-Dimensional Electron and Hole Systems**

by

Roland Winkler

(Springer Tracts in Modern Physics Vol. 191, Springer, Berlin 2003)

Dear Readers of the Book

I apologize for the misprints that escaped my notice before releasing the manuscript to the printer. Below you find a list of errata which I am aware of today. (I did not include in the list obvious typographic errors which do not cause confusion.) I am grateful to A. E. Botha, S. Chesi, H.-A. Engel, and B. Foreman for pointing out misprints.

I would appreciate if you could inform me of any further errors you might encounter. Please send them to my e-mail address given below. The newest update of errata is available at

<http://www.physics.niu.edu/~winkler/research/stmp.pdf>

<http://www.nano.uni-hannover.de/~winkler/research/stmp.pdf>

<http://www.tfkp.physik.uni-erlangen.de/~winkler/research/stmp.pdf>

April 26, 2006

Roland Winkler

e-mail: [winkler@physics.niu.edu](mailto:winkler@physics.niu.edu)

[winkler@nano.uni-hannover.de](mailto:winkler@nano.uni-hannover.de)



[roland.winkler@physik.uni-erlangen.de](mailto:roland.winkler@physik.uni-erlangen.de)

**p. 22** According to Koster et al. [4] the compatibility relations between the irreducible representations of  $O_h$  and  $T_d$  read:

$O_h$		$T_d$
$\Gamma_1^+$	$\rightarrow$	$\Gamma_1$
$\Gamma_2^-$	$\rightarrow$	$\Gamma_1$
$\Gamma_4^-$	$\rightarrow$	$\Gamma_5$
$\Gamma_5^+$	$\rightarrow$	$\Gamma_5$
$\Gamma_6^-$	$\rightarrow$	$\Gamma_7$
$\Gamma_7^+$	$\rightarrow$	$\Gamma_6$

Accordingly, Table 3.1 should read:

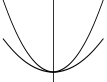
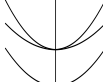
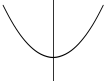
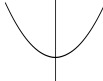
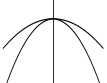
**Table 3.1.** Symmetry classification of the bands in the extended Kane model

Single group		Double group	
$O_h/T_d$	Full rotation group $\mathcal{R}$	$O_h/T_d$	$O_h/T_d$
	$\Gamma_4^-/\Gamma_5^- \leftarrow l=1 \quad (\mathcal{D}_1^-)$ p antibonding	$\nearrow j=3/2 \quad (\mathcal{D}_{3/2}^-) \rightarrow \Gamma_8^-/\Gamma_8$ $\searrow j=1/2 \quad (\mathcal{D}_{1/2}^-) \rightarrow \Gamma_6^-/\Gamma_7$	
	$\Gamma_2^-/\Gamma_1^- \leftarrow l=0 \quad (\mathcal{D}_0^-)$ s antibonding	$\rightarrow j=1/2 \quad (\mathcal{D}_{1/2}^-) \rightarrow \Gamma_7^-/\Gamma_6$	
	$\Gamma_5^+/\Gamma_5^+ \leftarrow l=1 \quad (\mathcal{D}_1^+)$ p bonding	$\nearrow j=3/2 \quad (\mathcal{D}_{3/2}^+) \rightarrow \Gamma_8^+/\Gamma_8$ $\searrow j=1/2 \quad (\mathcal{D}_{1/2}^+) \rightarrow \Gamma_7^+/\Gamma_7$	

**p. 41** The third line below Eq. (4.10): ... the number of states per unit energy range  $\pm dE$  and ...

**p. 41** Eq. (4.11) should read:

$$D(E) = \pm \frac{1}{\mathcal{L}^2} \frac{d}{dE} \mathcal{N}(E) = \sum_{\alpha, \sigma} \int \frac{d^2 k_{\parallel}}{(2\pi)^2} \delta[E - E_{\alpha\sigma}(\mathbf{k}_{\parallel})]. \quad (4.11)$$

**p. 41** Eq. (4.13) should read:

$$\frac{m_{\alpha\sigma}^*(E)}{m_0} = 4\pi \frac{\hbar^2}{2m_0} D_{\alpha\sigma}(E) = \frac{1}{\pi} \frac{\hbar^2}{2m_0} \int d^2 k_{\parallel} \delta[E - E_{\alpha\sigma}(\mathbf{k}_{\parallel})]. \quad (4.13)$$

**p. 43** First paragraph Sec. 4.4: Citation numbers corrected

... Most publications on the calculation of Landau levels in 2D hole systems have restricted themselves to the axial approximation (see Sect. 3.6) to Luttinger's  $4 \times 4 \mathbf{k} \cdot \mathbf{p}$  model [7,8]. In [38], the split-off valence band  $\Gamma_7^v$  ... Few publications [23,37,41,42] have analyzed Landau levels beyond the axial approximation. ...

**p. 46** Eq. (4.31) should read (sign reversed)

$$\psi_{\alpha N \sigma}(\mathbf{r}) = \sum_n |L_n = N - m_n - \frac{3}{2}\rangle \xi_{m_n}^{\alpha N \sigma}(z) u_{n \mathbf{0}}(\mathbf{r}) \quad (4.31)$$

**p. 46** Eq. (4.32b) should read (sign reversed)

$$\Psi_{\alpha N \sigma}(\mathbf{r}) = \sum_{\alpha', N, \sigma'} c_{\alpha N \sigma}^{\alpha' N \sigma'} \sum_n |N - m_n - \frac{3}{2}\rangle \xi_{m_n}^{\alpha' N \sigma'}(z) u_{n \mathbf{0}}(\mathbf{r}). \quad (4.32b)$$

**p. 54** End of second paragraph: If expressed in a basis of eigenstates of  $J_z$  all four eigenstates of  $J_x$  and  $J_y$  are a mixture of both HH and LH states.

**p. 66** Eq. (5.13) should read

$$\tilde{\psi}_c = \left[ 1 + \frac{P^2}{6} \left( \frac{2k^2 - (e/\hbar) \boldsymbol{\sigma} \cdot \mathbf{B}}{E_0^2} + \frac{k^2 + (e/\hbar) \boldsymbol{\sigma} \cdot \mathbf{B}}{(E_0 + \Delta_0)^2} \right) \right] \psi_c \quad (5.13)$$

**p. 71** Footnote 2 should read: Strictly speaking, even for the diamond structure only  $T_d$  but not  $O_h$  is a subgroup of the space group. The reason is that the diamond structure has a *nonsymmorphic* space group with point group  $O_h$ , i.e. the symmetry operations in  $O_h$  must be combined with a nonprimitive translation of the translation subgroup of the diamond structure in order to map the diamond structure onto itself. Nevertheless, ...

**p. 116** A minus sign is missing in the body of Fig. 6.17 (only in the printed version of the book).

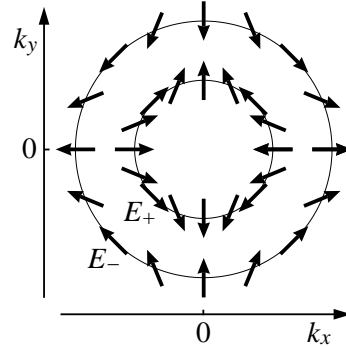

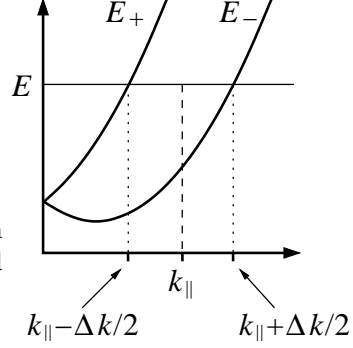

**p. 118** Two minus signs are missing in the body of Fig. 6.18 (only in the printed version of the book).

**p. 146** Eq. (7.19a) should read (several signs reversed):

$$\begin{aligned} \mathcal{H}_{[001]}^{\text{HH}} = & -\frac{3}{2}q\mu_{\text{B}} (B_x\sigma_x - B_y\sigma_y) \\ & + \mathcal{Z}_{[001]}^{\text{HH}} \mu_{\text{B}}^3 \{ \gamma_2 [(B_x^3 - B_x B_y^2)\sigma_x - (B_y^3 - B_y B_x^2)\sigma_y] \\ & - 2\gamma_3 [B_x B_y^2 \sigma_x - B_y B_x^2 \sigma_y] \}, \end{aligned} \quad (7.19a)$$

**p. 146** Eq. (7.19b) should read:

$$\begin{aligned} \mathcal{Z}_{[001]}^{\text{HH}} = & \frac{6im_0}{\hbar^2} \left( \kappa \sum_{\alpha} \frac{\langle h_1 | z^2 | l_{\alpha} \rangle \langle l_{\alpha} | \{ \mathbf{e}_z, z \} | h_1 \rangle + \langle h_1 | \{ \mathbf{e}_z, z \} | l_{\alpha} \rangle \langle l_{\alpha} | z^2 | h_1 \rangle}{E_1^h - E_{\alpha}^l} \right. \\ & \left. + 2\gamma_3 \sum_{\alpha} \frac{\langle h_1 | z^2 | l_{\alpha} \rangle \langle l_{\alpha} | \{ \mathbf{e}_z, z \} | h_1 \rangle - \langle h_1 | \{ \mathbf{e}_z, z \} | l_{\alpha} \rangle \langle l_{\alpha} | z^2 | h_1 \rangle}{E_1^h - E_{\alpha}^l} \right). \end{aligned} \quad (7.19b)$$

**p. 147** Eq. (7.20) should read (several signs reversed):

$$\mathcal{Z}_{[001]}^{\text{HH}} = \left( \frac{w^2 m_0}{\pi^2 \hbar^2} \right)^2 \left[ \frac{\kappa}{2\gamma_2} (\pi^2 - 6) - \frac{27\gamma_3}{16\gamma_1 + 40\gamma_2} \right]. \quad (7.20)$$

**p. 147** Eq. (7.22) should read ( $\mu_{\text{B}}$ 's added)

$$\begin{aligned} \mathcal{H}_{[001]}^{\text{HH}} = & z_{51}^{7h7h} \mu_{\text{B}} (B_x k_x^2 \sigma_x - B_y k_y^2 \sigma_y) + z_{52}^{7h7h} \mu_{\text{B}} (B_x k_y^2 \sigma_x - B_y k_x^2 \sigma_y) \\ & + z_{53}^{7h7h} \mu_{\text{B}} \{ k_x, k_y \} (B_y \sigma_x - B_x \sigma_y), \end{aligned} \quad (7.22)$$

**p. 147** Eq. (7.23) should read

$$z_{51}^{7h7h} = -\frac{3}{2}\kappa\gamma_2 \mathcal{Z}_1 + 6\gamma_3^2 \mathcal{Z}_2, \quad (7.23a)$$

$$z_{52}^{7h7h} = \frac{3}{2}\kappa\gamma_2 \mathcal{Z}_1 - 6\gamma_2\gamma_3 \mathcal{Z}_2, \quad (7.23b)$$

$$z_{53}^{7h7h} = 3\kappa\gamma_3 \mathcal{Z}_1 - 6\gamma_3 (\gamma_2 + \gamma_3) \mathcal{Z}_2, \quad (7.23c)$$

**p. 147** Eq. (7.24) should read

$$\mathcal{Z}_1 = i \frac{\hbar^2}{m_0} \frac{\langle h_1 | [k_z, z] | l_1 \rangle \langle l_1 | h_1 \rangle + \langle h_1 | l_1 \rangle \langle l_1 | [k_z, z] | h_1 \rangle}{E_1^h - E_1^l}, \quad (7.24a)$$

$$\mathcal{Z}_2 = i \frac{\hbar^2}{m_0} \sum_{\alpha} \frac{\langle h_1 | k_z | l_{\alpha} \rangle \langle l_{\alpha} | z | h_1 \rangle - \langle h_1 | z | l_{\alpha} \rangle \langle l_{\alpha} | k_z | h_1 \rangle}{E_1^h - E_{\alpha}^l}. \quad (7.24b)$$

**p. 147** Eq. (7.25) should read

$$\mathcal{Z}_1 = \frac{w^2}{\pi^2 \gamma_2}, \quad (7.25a)$$

$$\mathcal{Z}_2 = \frac{512w^2}{27\pi^4 (3\gamma_1 + 10\gamma_2)}. \quad (7.25b)$$

**p. 167** Two minus signs are missing in the body of Fig. 8.12 (only in the printed version of the book).

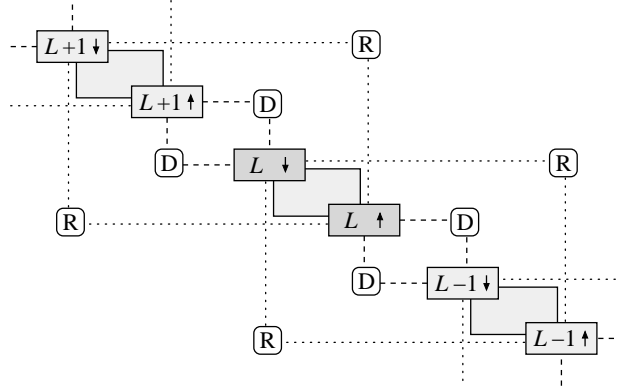

**p. 187** Eq. (9.14b) and Eq. (9.14c) should read:

$$\mathcal{H}_-^b = \frac{i}{8} [c(3c^2 - 1)(k_-^3 + \{k_+, k_-, k_+\} - 4k_+ k_z^2) + 6cs^2(\{k_-, k_+, k_-\} - 4k_- k_z^2)], \quad (9.14b)$$

$$\mathcal{H}_z^b = \frac{i}{16} [3s(c^2 + 1)(k_-^3 - k_+^3) + s(3c^2 - 1)(\{k_-, k_+, k_-\} - \{k_+, k_-, k_+\}) + 4s(3c^2 - 1)(k_+ - k_-)k_z^2], \quad (9.14c)$$

**p. 202** A minus sign is missing in the body of Fig. B.1 (only in the printed version of the book).

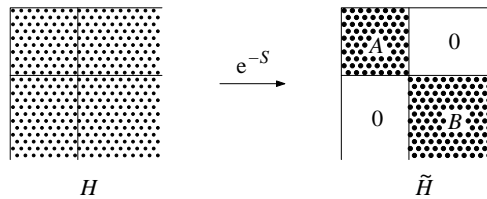

**p. 209** In Table C.2,  $T_{yz}$  should read

$$T_{yz} = \frac{i}{2\sqrt{6}} \begin{pmatrix} -1 & 0 & -\sqrt{3} & 0 \\ 0 & \sqrt{3} & 0 & 1 \end{pmatrix}$$

**p. 210** Table C.3(c) should read (see above the corrected Table 3.1.):

$\Gamma_8^{c-}(\Gamma_8^c)$	$\Gamma_6^{c-}(\Gamma_7^c)$	$\Gamma_7^{c-}(\Gamma_6^c)$	$\Gamma_8^{v+}(\Gamma_8^v)$	$\Gamma_7^{v+}(\Gamma_7^v)$	
+	+	+	-	-	$\Gamma_8^{c-}(\Gamma_8^c)$
	+	+	-	-	$\Gamma_6^{c-}(\Gamma_7^c)$
		+	-	-	$\Gamma_7^{c-}(\Gamma_6^c)$
			+	+	$\Gamma_8^{v+}(\Gamma_8^v)$
				+	$\Gamma_7^{v+}(\Gamma_7^v)$